

**Features**

- Super high density cell design for extremely low  $R_{DS(ON)}$
- Exceptional on-resistance and maximum DC current capability

**Product Summary**

$V_{DS}$	$R_{DS(ON)}$ MAX	$I_D$ MAX
100V	95mΩ@10V	10A
	120mΩ@4.5V	

**Application**

- Power Management in Note book
- DC/DC Converter
- Load Switch
- LCD Display inverter

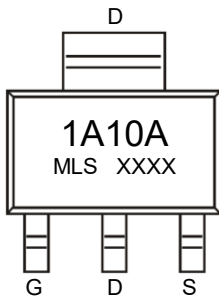

1A10A : Device code  
 XXXX : Code

Marking and pin assignment



SOT-223 top view

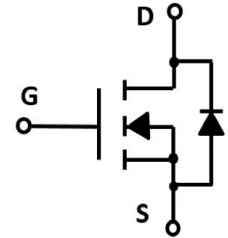

Schematic diagram



Pb-Free



RoHS



Halogen-Free

**Absolute Maximum Ratings (TA=25°C unless otherwise noted)**

Symbol	Parameter	Rating	Unit
--------	-----------	--------	------

**Common Ratings (TC=25°C Unless Otherwise Noted)**

$V_{DS}$	Drain-Source Breakdown Voltage	100	V
$V_{GS}$	Gate-Source Voltage	±20	V
$T_J$	Maximum Junction Temperature	150	°C
$T_{STG}$	Storage Temperature Range	-50 to 155	°C
$I_S$	Diode Continuous Forward Current	10	A

**Mounted on Large Heat Sink**

$I_{DM}$	Pulse Drain Current Tested	43	A	
$I_D$	Continuous Drain Current	$T_c=25^\circ\text{C}$	10	A
$P_D$	Maximum Power Dissipation	$T_c=25^\circ\text{C}$	3	W
$R_{\theta JA}$	Thermal Resistance Junction-Ambient	40	°C/W	

**Ordering Information (Example)**

Type	Package	Marking	Minimum Package(pcs)	Inner Box Quantity(pcs)	Outer Carton Quantity(pcs)	Delivery Mode
MT1A10A	SOT-223	1A10A	2,500	5,000	35,000	13"reel

Electrical Characteristics (T <sub>J</sub> =25°C unless otherwise noted)						
Symbol	Parameter	Condition	Min	Typ	Max	Unit
<b>Static Electrical Characteristics @ T<sub>J</sub> = 25°C (unless otherwise stated)</b>						
BV <sub>(BR)DSS</sub>	Drain-Source Breakdown Voltage	V <sub>GS</sub> =0V, I <sub>D</sub> =250μA	100	--	--	V
I <sub>DSS</sub>	Zero Gate Voltage Drain Current	V <sub>DS</sub> =100V, V <sub>GS</sub> =0V	--	--	1.0	μA
I <sub>GSS</sub>	Gate-Body Leakage Current	V <sub>GS</sub> =±20V, V <sub>DS</sub> =0V	--	--	±100	nA
V <sub>GS(th)</sub>	Gate Threshold Voltage	V <sub>DS</sub> =V <sub>GS</sub> , I <sub>D</sub> =250μA	1.2	1.9	2.5	V
R <sub>DS(on)</sub>	Drain-Source On-State Resistance	V <sub>GS</sub> =10V, I <sub>D</sub> =10A	--	75	95	mΩ
		V <sub>GS</sub> =4.5V, I <sub>D</sub> =8A	--	90	120	mΩ
<b>Dynamic Electrical Characteristics @ T<sub>J</sub> = 25°C (unless otherwise stated)</b>						
C <sub>ISS</sub>	Input Capacitance	V <sub>DS</sub> =15V, V <sub>GS</sub> =0V, f=1MHz	--	1230	--	pF
C <sub>OSS</sub>	Output Capacitance		--	50	--	pF
C <sub>RSS</sub>	Reverse Transfer Capacitance		--	40	--	pF
<b>Switching Characteristics</b>						
Q <sub>g</sub>	Total Gate Charge	V <sub>DD</sub> =50V, I <sub>D</sub> =10A, V <sub>GS</sub> =10V	--	22	--	nC
Q <sub>gs</sub>	Gate Source Charge		--	4	--	nC
Q <sub>gd</sub>	Gate Drain Charge		--	3.5	--	nC
t <sub>d(on)</sub>	Turn-on Delay Time	V <sub>DD</sub> =50V, I <sub>D</sub> =10A, V <sub>GS</sub> =10V, R <sub>G</sub> =3Ω	--	4.5	--	nS
t <sub>r</sub>	Turn-on Rise Time		--	20	--	nS
t <sub>d(off)</sub>	Turn-Off Delay Time		--	20	--	nS
t <sub>f</sub>	Turn-Off Fall Time		--	15	--	nS
<b>Source- Drain Diode Characteristics</b>						
V <sub>SD</sub>	Forward on voltage	T <sub>J</sub> =25°C, I <sub>S</sub> =10A	--	--	1.2	V

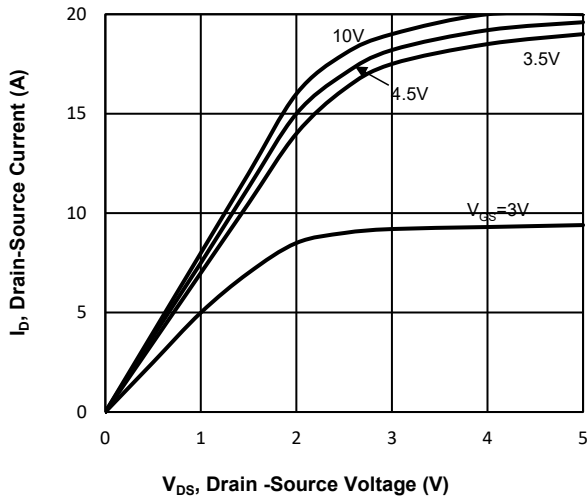
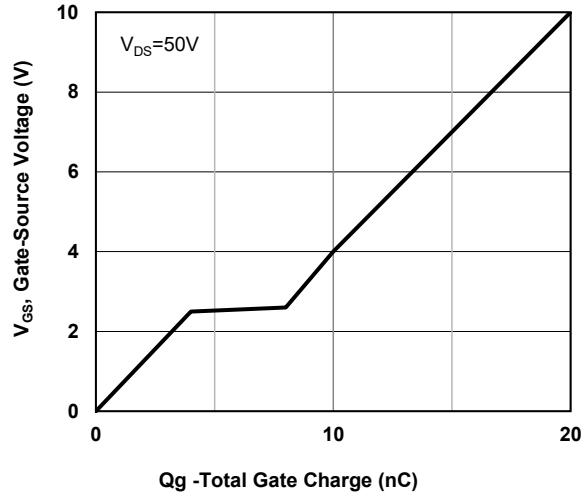
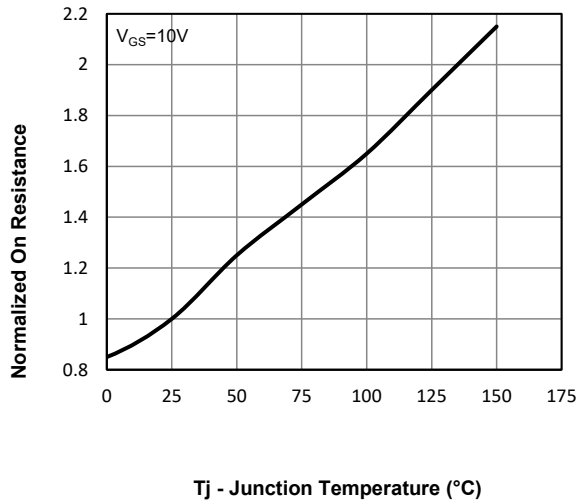
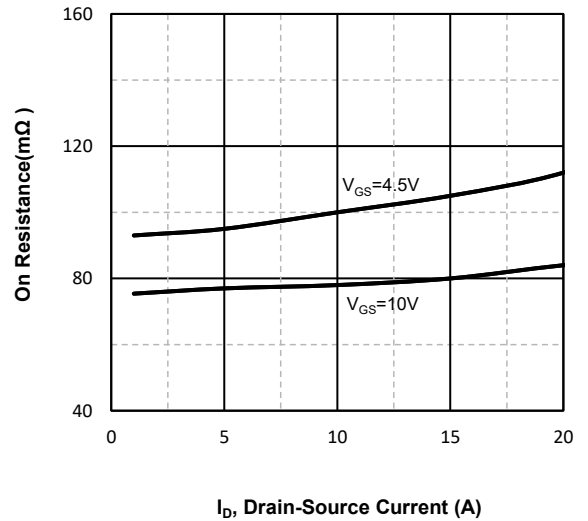
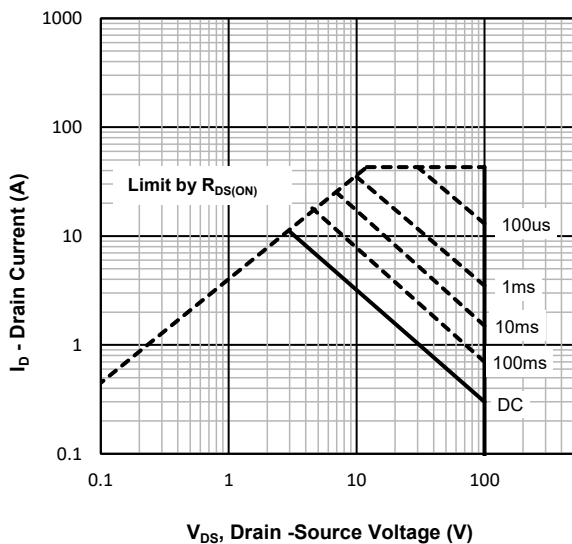
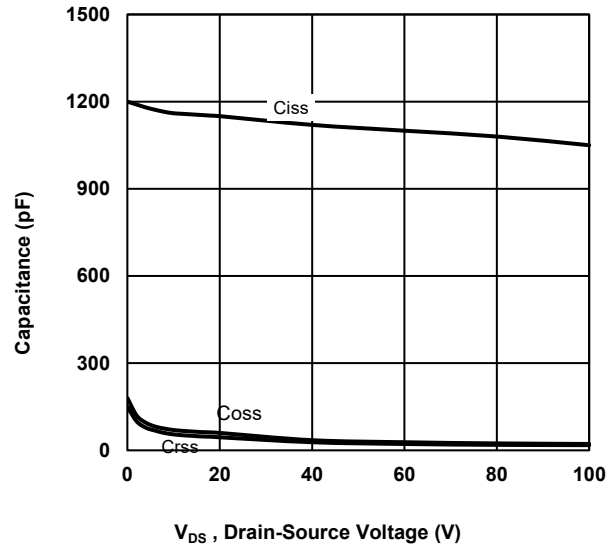
**Typical Operating Characteristics**

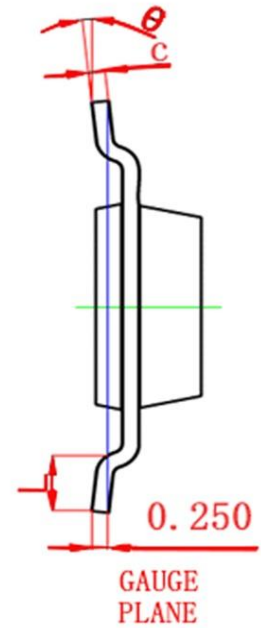
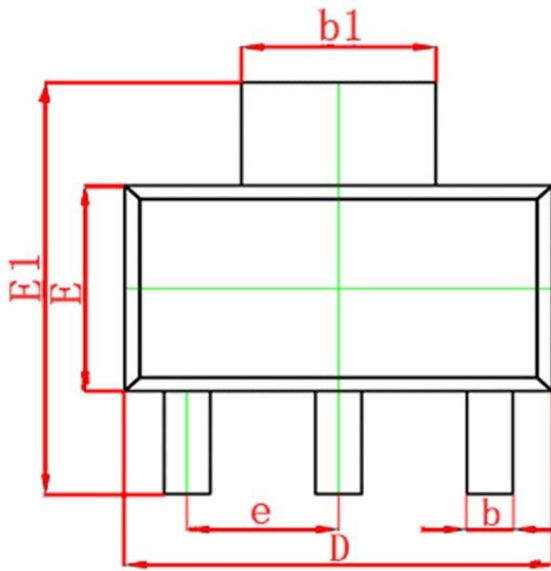
**Fig1. Typical Output Characteristics**

**Fig2. Typical Gate Charge Vs. Gate-Source Voltage**

**Fig3. Normalized On-Resistance Vs. Temperature**

**Fig4. On-Resistance Vs. Drain-Source Current**

**Fig5. Maximum Safe Operating Area**

**Fig6 Typical Capacitance Vs. Drain-Source Voltage**

**SOT-223 Package information**

Symbol	Dimensions in Millimeters(mm)		Dimensions In Inches	
	Min	Max	Min	Max
A	--	1.800	--	0.071
A1	0.020	0.100	0.001	0.004
A2	1.500	1.700	0.059	0.067
b	0.660	0.840	0.026	0.033
b1	2.900	3.100	0.114	0.122
c	0.230	0.350	0.009	0.014
D	6.300	6.700	0.248	0.264
E	3.300	3.700	0.130	0.146
E1	6.700	7.300	0.264	0.287
e	2.300(BSC)		0.091(BSC)	
L	0.750	--	0.030	--
$\theta$	0°	10°	0°	10°