

Features

- High power and current handing capability
- Lead free product is acquired
- Surface mount package

Product Summary

V_{DS}	$R_{DS(ON)}$ TYP	I_D
20V	20mΩ@10V	6A
	27mΩ@4.5V	

Application

- Battery protection
- Load switch
- Power management



TSSOP-8 top view

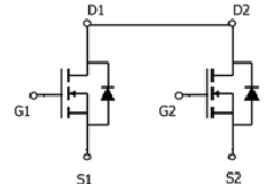

Schematic diagram

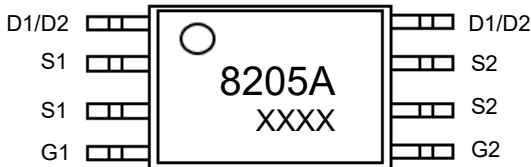

Marking and Pin assignment

8205A: Device code
 XXXX: Code



Halogen-Free

Absolute Maximum Ratings (TA=25°C unless otherwise noted)

Symbol	Parameter	Rating	Unit
--------	-----------	--------	------

Common Ratings (TC=25°C Unless Otherwise Noted)

V_{DS}	Drain-Source Breakdown Voltage	20	V
V_{GS}	Gate-Source Voltage	±12	V
T_J	Maximum Junction Temperature	150	°C
T_{STG}	Storage Temperature Range	-55 to 150	°C
I_S	Diode Continuous Forward Current	$T_c=25^\circ\text{C}$ 6	A

Mounted on Large Heat Sink

I_{DM}	Pulse Drain Current Tested	$T_c=25^\circ\text{C}$ 25	A
I_D	Continuous Drain Current	$T_c=25^\circ\text{C}$ 6	A
P_D	Maximum Power Dissipation	$T_c=25^\circ\text{C}$ 1.5	W
$R_{\theta JA}$	Thermal Resistance Junction-Ambient	80	°C/W

Ordering Information (Example)

Type	Package	Marking	Minimum Package(pcs)	Inner Box Quantity(pcs)	Outer Carton Quantity(pcs)	Delivery Mode
MS8205A	TSSOP-8	8205A	3,000	6,000	42,000	13"reel

Electrical Characteristics (T _J =25°C unless otherwise noted)						
Symbol	Parameter	Condition	Min	Typ	Max	Unit
Static Electrical Characteristics @ T_J = 25°C (unless otherwise stated)						
B _{V(BR)DSS}	Drain-Source Breakdown Voltage	V _{GS} =0V, I _D =250μA	20	--	--	V
I _{DSS}	Zero Gate Voltage Drain Current	V _{DS} =20V, V _{GS} =0V	--	--	1	μA
I _{GSS}	Gate-Body Leakage Current	V _{GS} =±12V, V _{DS} =0V	--	--	±100	nA
V _{GS(th)}	Gate Threshold Voltage	V _{DS} =V _{GS} , I _D =250μA	0.5	0.7	1.2	V
R _{DS(on)}	Drain-Source On-State Resistance	V _{GS} =10V, I _D =6A	--	20	23	mΩ
		V _{GS} =4.5V, I _D =5A	--	27	35	mΩ
Dynamic Electrical Characteristics @ T_J = 25°C (unless otherwise stated)						
C _{ISS}	Input Capacitance	V _{DS} =10V, V _{GS} =0V, f=1MHz	--	889	--	pF
C _{OSS}	Output Capacitance		--	215	--	pF
C _{RSS}	Reverse Transfer Capacitance		--	98	--	pF
Switching Characteristics						
Q _g	Total Gate Charge	V _{DS} =10V, I _D =6A, V _{GS} =4.5V	--	11.6	--	nC
Q _{gs}	Gate Source Charge		--	2.3	--	nC
Q _{gd}	Gate Drain Charge		--	1.1	--	nC
t _{d(on)}	Turn-on Delay Time	V _{DD} =10V, I _D =6A, V _{GS} =4.5V, R _G =6Ω	--	10	--	nS
t _r	Turn-on Rise Time		--	11	--	nS
t _{d(off)}	Turn-Off Delay Time		--	34	--	nS
t _f	Turn-Off Fall Time		--	31	--	nS
Source- Drain Diode Characteristics						
V _{SD}	Forward on voltage	T _J =25°C, I _S =6A	--	--	1.2	V

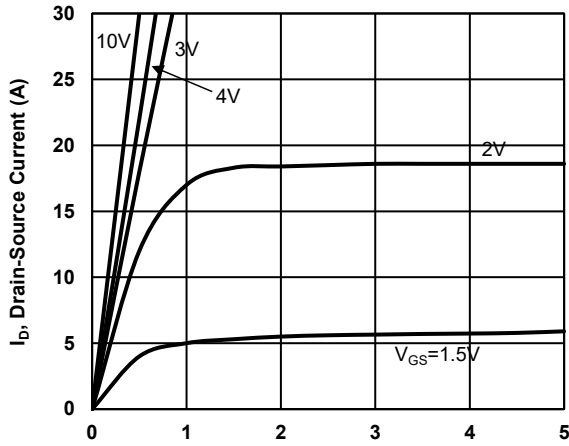
Typical Operating Characteristics

V_{DS} , Drain -Source Voltage (V)
Fig1. Typical Output Characteristics

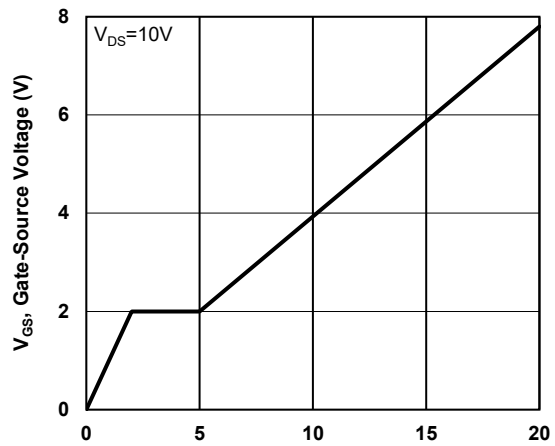

Q_g -Total Gate Charge (nC)
Fig2. Typical Gate Charge Vs. Gate-Source Voltage

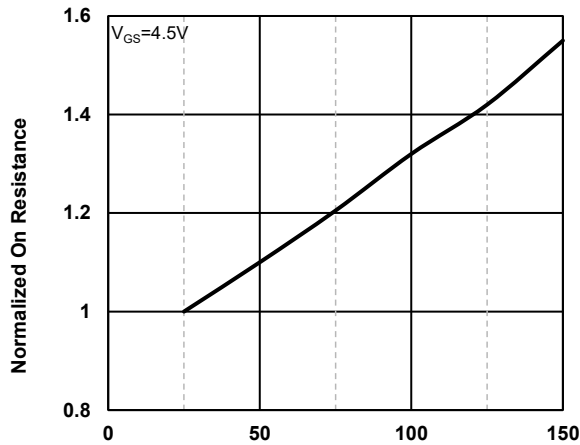

T_j - Junction Temperature ($^{\circ}C$)
Fig3. Normalized On-Resistance Vs. Temperature

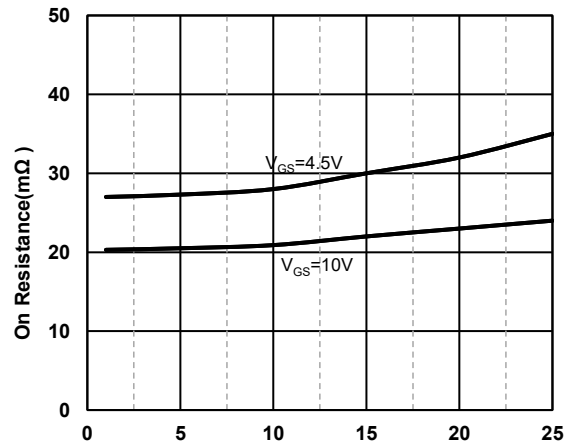

I_D , Drain-Source Current (A)
Fig4. On-Resistance Vs. Drain-Source Current

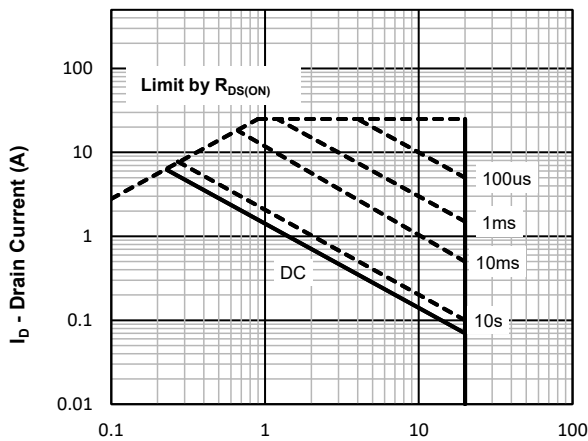

V_{DS} , Drain -Source Voltage (V)
Fig5. Maximum Safe Operating Area

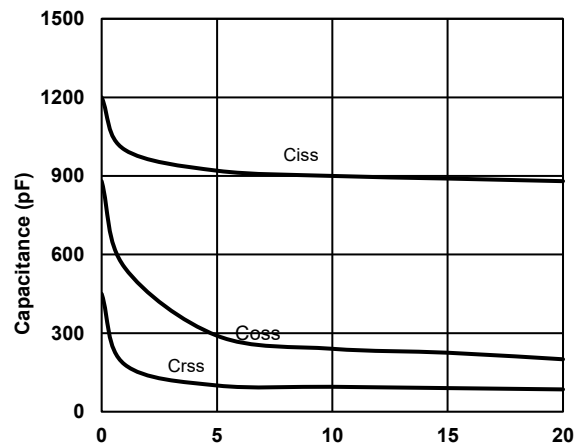

V_{DS} , Drain-Source Voltage (V)
Fig6 Typical Capacitance Vs. Drain-Source Voltage

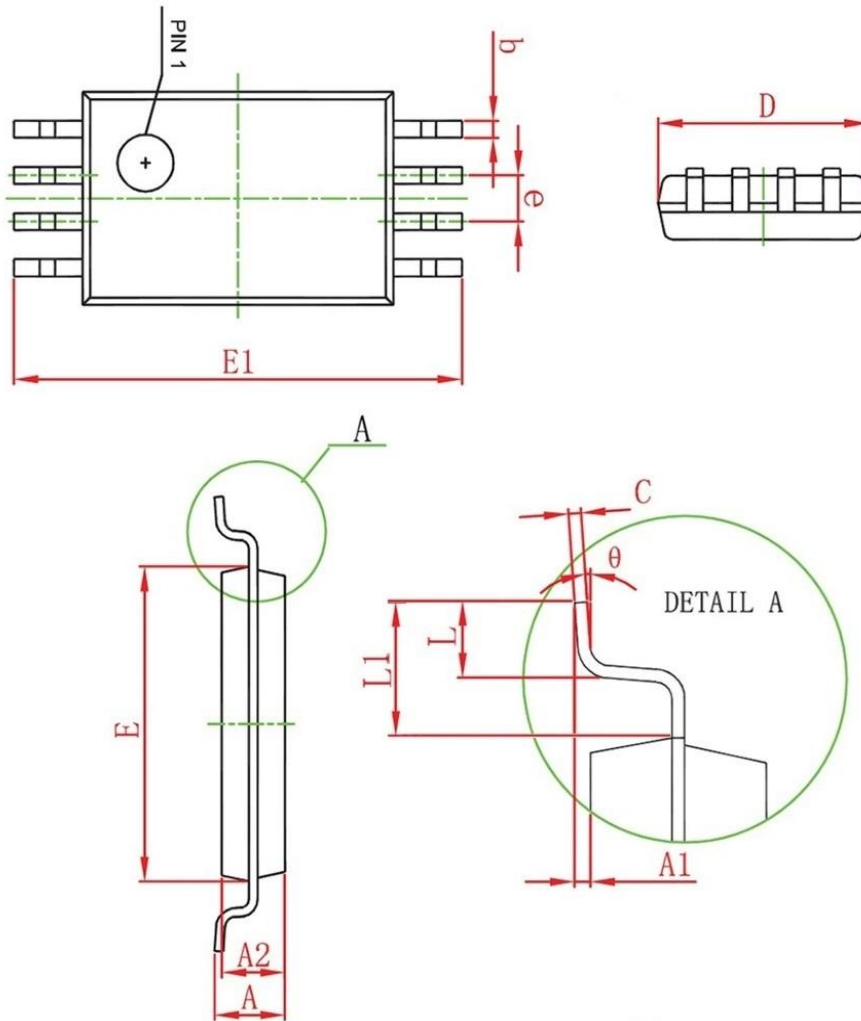
TSSOP-8 Package information

Symbol	Dimensions in Millimeters(mm)		Dimensions in Inches	
	Min	Max	Min	Max
A	1.000	1.200	0.039	0.047
A1	0.020	0.180	0.000	0.007
A2	0.900	1.100	0.035	0.043
b	0.170	0.270	0.006	0.010
c	0.122	0.132	0.004	0.005
D	2.870	3.070	0.112	0.120
e	0.65BSC		0.025BSC	
E	4.300	4.500	0.169	0.177
E1	6.200	6.600	0.244	0.259
L	0.400	0.800	0.015	0.031
L1	1.00BSC		0.039BSC	
Ø1	0.500	0.700	0.001	0.027
θ	0°	10°	0°	10°