

Features

- Trench Power LV MOSFET technology
- High density cell design for Low $R_{DS(ON)}$
- High Speed switching

Product Summary

V_{DS}	$R_{DS(ON)}$ TYP	I_D
-30V	8.5m Ω @-10V	-40A
	12m Ω @-4.5V	

Application

- Battery protection
- Load switch
- Power management

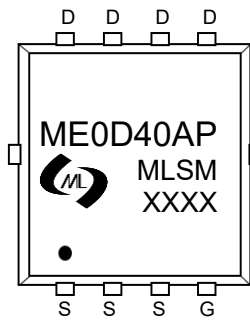

ME0D40AP : Device code
 XXXX : Code

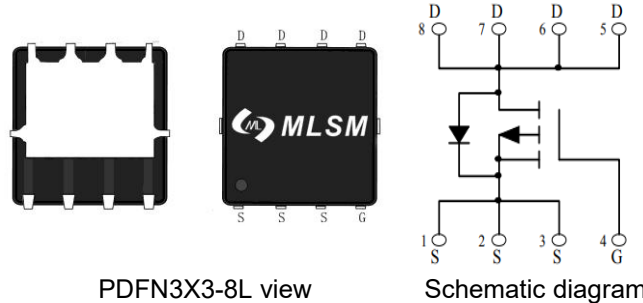

PDFN3X3-8L view

Schematic diagram



Halogen-Free

Marking and pin assignment

Absolute Maximum Ratings (TA=25°C unless otherwise noted)				
Symbol	Parameter	Rating	Unit	
Common Ratings (TC=25°C Unless Otherwise Noted)				
V_{DS}	Drain-Source Breakdown Voltage	-30	V	
V_{GS}	Gate-Source Voltage	± 20	V	
E_{AS}	Single pulse avalanche energy	156	mJ	
T_J, T_{STG}	Storage Temperature Range	-55 to 175	°C	
I_S	Diode Continuous Forward Current	-40	$T_C=25^\circ C$	A
Mounted on Large Heat Sink				
I_{DM}	Pulse Drain Current Tested	-180	$T_C=25^\circ C$	A
I_D	Continuous Drain Current	-40	$T_C=25^\circ C$	A
P_D	Maximum Power Dissipation	30	$T_C=25^\circ C$	W
$R_{\theta JA}$	Thermal Resistance Junction-Ambient	55	°C/W	

Ordering Information (Example)

Type	Package	Marking	Minimum Package(pcs)	Inner Box Quantity(pcs)	Outer Carton Quantity(pcs)	Delivery Mode
ME0D40AP	PDFN3X3-8L	ME0D40AP	5,000	10,000	70,000	13" reel

Electrical Characteristics (T _J =25°C unless otherwise noted)						
Symbol	Parameter	Condition	Min	Typ	Max	Unit
Static Electrical Characteristics @ T_J = 25°C (unless otherwise stated)						
BV _{(BR)DSS}	Drain-Source Breakdown Voltage	V _{GS} =0V, I _D =-250μA	-30	--	--	V
I _{DSS}	Zero Gate Voltage Drain Current	V _{DS} =-30V, V _{GS} =0V	--	--	-1	μA
I _{GSS}	Gate-Body Leakage Current	V _{GS} =±20V, V _{DS} =0V	--	--	±100	nA
V _{GS(th)}	Gate Threshold Voltage	V _{DS} =V _{GS} , I _D =-250μA	-1.0	-1.5	-2.5	V
R _{DS(on)}	Drain-Source On-State Resistance	V _{GS} =-10V, I _D =-15A	--	8.5	10	mΩ
		V _{GS} =-4.5V, I _D =-10A	--	12	14	mΩ
Dynamic Electrical Characteristics @ T_J = 25°C (unless otherwise stated)						
C _{ISS}	Input Capacitance	V _{DS} =-15V, V _{GS} =0V, f=1MHz	--	1950	--	pF
C _{OSS}	Output Capacitance		--	255	--	pF
C _{RSS}	Reverse Transfer Capacitance		--	170	--	pF
Q _g	Total Gate Charge	V _{DS} =-15V, I _D =-12A, V _{GS} =-10V	--	37	--	nC
Q _{gs}	Gate Source Charge		--	6	--	nC
Q _{gd}	Gate Drain Charge		--	9	--	nC
Switching Characteristics						
t _{d(on)}	Turn-on Delay Time	V _{DS} =-15V, R _L =1Ω, V _{GS} =-10V, R _G =3Ω	--	8	--	nS
t _r	Turn-on Rise Time		--	27	--	nS
t _{d(off)}	Turn-Off Delay Time		--	68	--	nS
t _f	Turn-Off Fall Time		--	39	--	nS
Source- Drain Diode Characteristics						
V _{SD}	Forward on voltage	T _J =25°C, I _S =-15A	--	--	-1.2	V

Typical Operating Characteristics

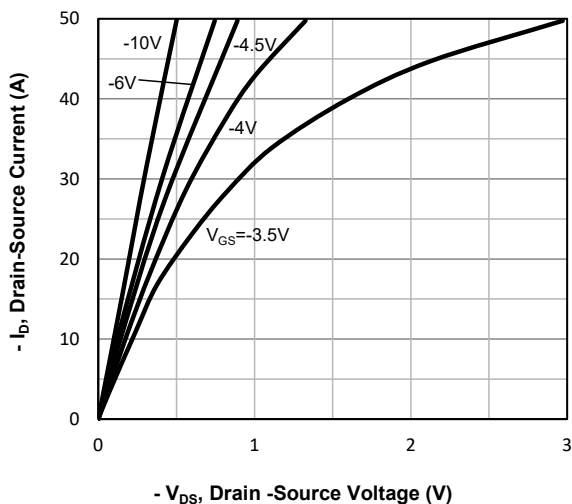

Fig1. Typical Output Characteristics

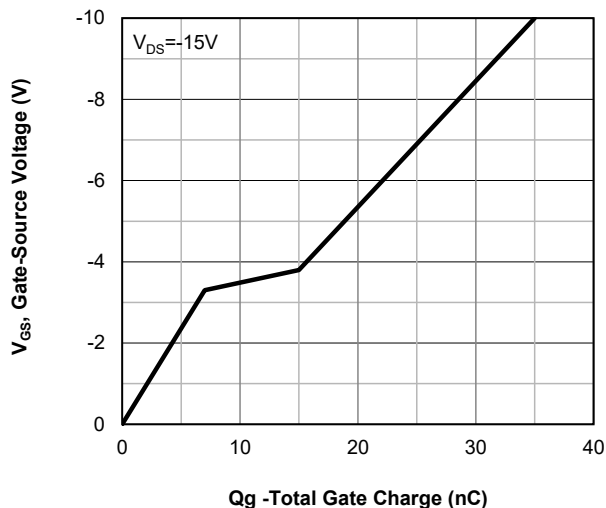

Fig2. Typical Gate Charge Vs. Gate-Source Voltage

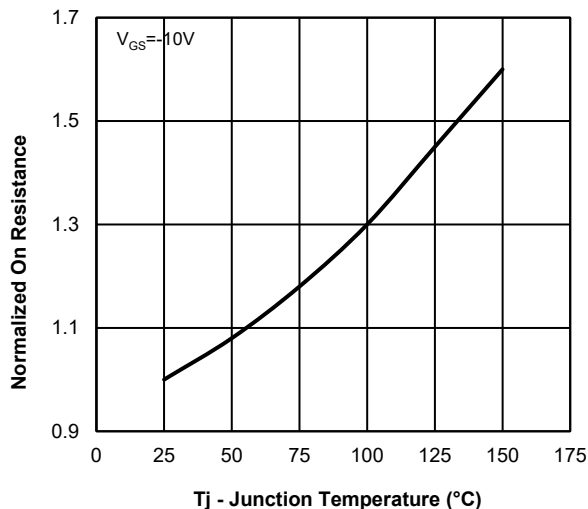

Fig3. Normalized On-Resistance Vs. Temperature

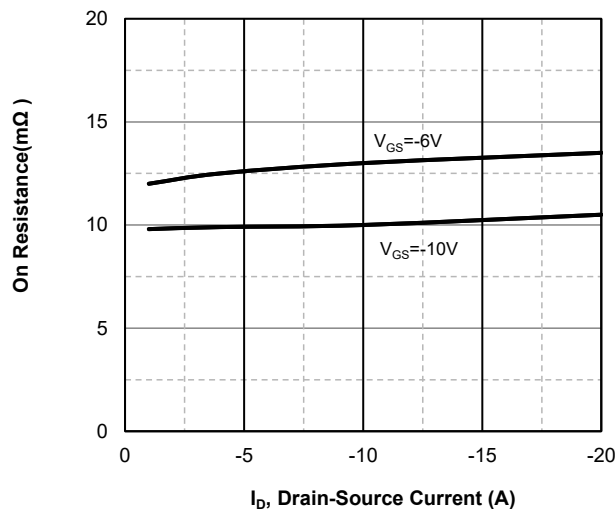

Fig4. On-Resistance Vs. Drain-Source Current

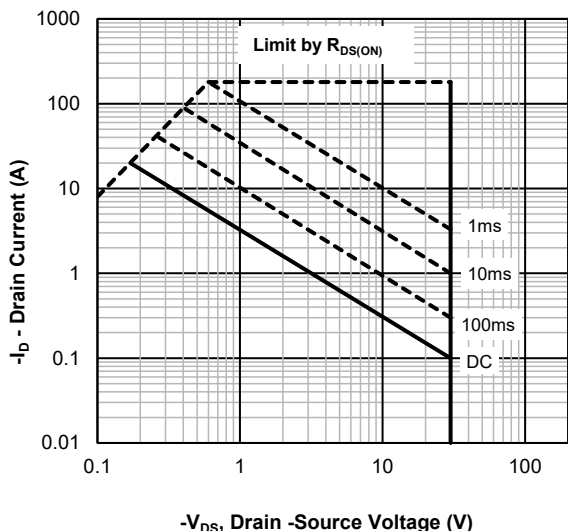

Fig5. Maximum Safe Operating Area

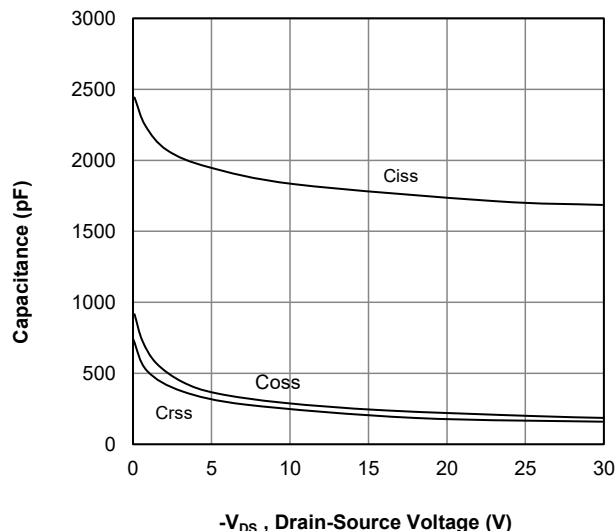
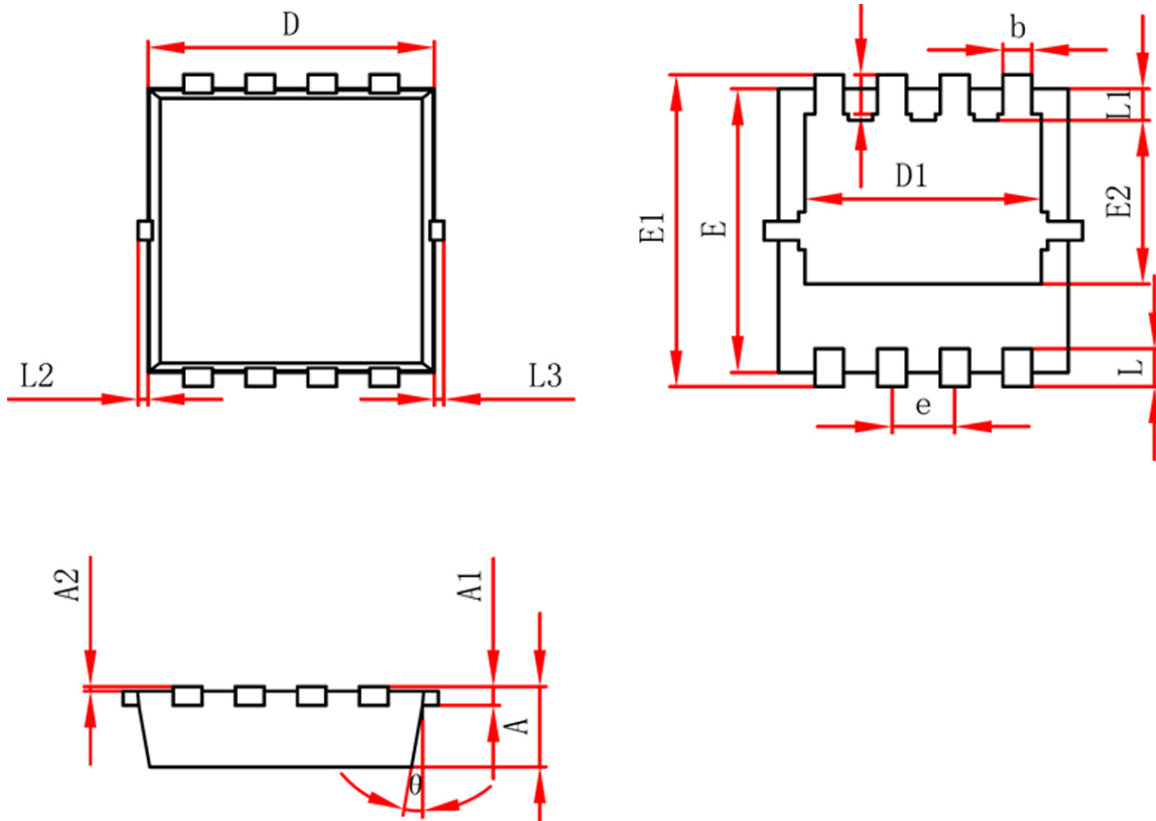

Fig6. Typical Capacitance Vs. Drain-Source Voltage

PDFN3X3-8L Package information

Symbol	Dimensions in Millimeters(mm)		Dimensions in Inches	
	Min	Max	Min	Max
A	0.750	0.850	0.030	0.034
A1	0.152 REF.		0.006 REF.	
A2	0~0.05		0~0.002	
D	2.950	3.150	0.117	0.125
D1	2.400	2.500	0.095	0.099
E	2.950	3.050	0.117	0.121
E1	3.250	3.350	0.129	0.132
E2	1.685	1.785	0.067	0.071
b	0.250	0.350	0.010	0.014
e	0.600	0.700	0.024	0.028
L	0.350	0.450	0.014	0.018
L1	0.325	0.425	0.013	0.017
L2	0~0.100		0~0.004	
L3	0~0.100		0~0.004	
H	0.365	0.465	0.014	0.018
θ	10°	12°	10°	12°